

IS LINE

ED. 13
UPD. 01



Alusic

STAIRS AND WALKWAYS

SCALE E PASSERELLE
ESCALERAS Y PASARELAS
ESCALIERS ET PASSERELLES
TREPPEN UND ÜBERSTIEGEN

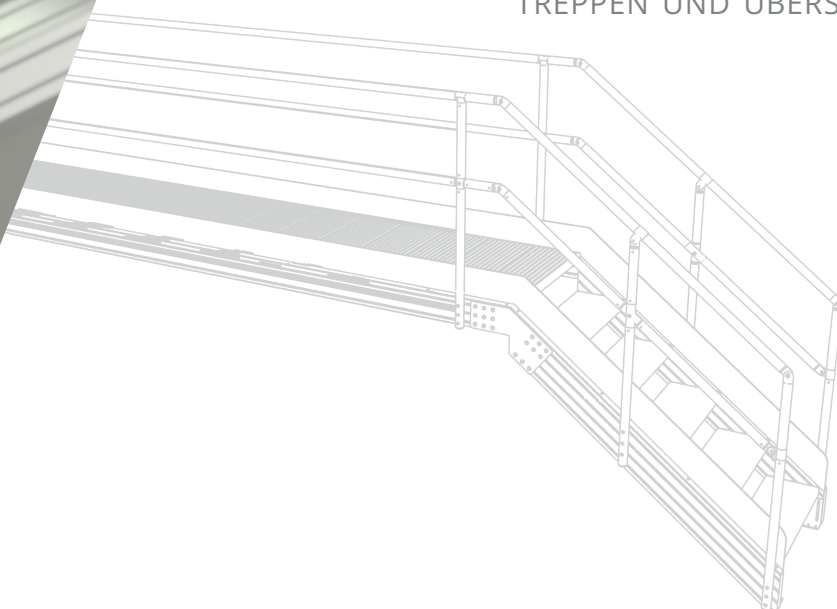

IS LINE



Alusic

STAIRS AND WALKWAYS

SCALE E PASSERELLE
ESCALERAS Y PASARELAS
ESCALIERS ET PASSERELLES
TREPPEN UND ÜBERSTIEGEN

EN

Alusic's range of profiles and accessories for stairs, walkways and crossover stairs incorporates a wide range of solutions for industrial applications. Wherever there is a need to cross over production lines, create walkways alongside machinery or changes of height, our modular profiles for creating stairs and landings, and practical handrail connection accessories, offer a quick, practical answer to all requirements. The stairway profile is self-supporting, meeting relevant standards, up to a width of 1200 mm with a centralised load of 150 kg or a distributed load of 200 kg/m2.

IT

La linea Alusic di profili e accessori per scale e passerelle comprende un'ampia gamma di soluzioni per applicazioni in campo industriale. Ovunque debbano essere creati degli scavalcamenti di linee di produzione, camminamenti a fianco di macchine o cambi di altimetria, i profili modulari per la realizzazione dei gradini dei pianerottoli e i pratici accessori per la giunzione dei corrimano offrono una risposta pratica e veloce ad ogni necessità. Il profilo scalino è autoportante secondo normativa fino ad una larghezza di 1200 mm con un carico al centro di 150 Kg o un carico distribuito di 200 Kg/m2.

ES

La línea Alusic de perfiles y accesorios para escaleras y pasarelas incluye una amplia gama de soluciones para aplicaciones en el ámbito industrial. Allí donde sea necesario crear pasarelas de franqueo de líneas de producción, corredores junto a máquinas o cambios de altura, los perfiles modulares para la realización de peldaños y rellanos y los prácticos accesorios para la unión de las barandillas ofrecen una respuesta práctica y rápida a cualquier necesidad. El perfil para escalón es autoportante según la normativa hasta una longitud de 1200 mm con una carga en el centro de 150 kg o una carga distribuida de 200 kg/m2.

FR

La ligne Alusic de profilés et accessoires pour escaliers et passerelles comprend une vaste gamme de solutions pour des applications en milieu industriel. Dans tous les cas où il est nécessaire de créer des voies de passage surmontant des lignes de production ou le long de machines, ou encore des points de franchissement de hauteurs différentes, les profilés modulaires pour la réalisation des marches de paliers et les accessoires pratiques de jonction des mains courantes offrent une réponse à la fois fonctionnelle et rapide à toute exigence. Le profilé de marche est autoportant, conformément aux normes, jusqu'à une longueur de 1200 mm avec une charge de 150 kg en position centrale ou une charge répartie de 200 kg/m2.

DE

Die Alusic-Produktlinie mit Profilen und Zubehör für Treppen und Überstiegen umfasst eine große Auswahl an Lösungen für Industrieanwendungen. Überall, wo Überstiegen von Produktionslinien, Wege neben Maschinen oder Höhenänderungen geschaffen werden müssen, stellen die modularen Profile für die Schaffung von Stufen und Treppenabsätzen und das praktische Zubehör für die Verbindung von Handläufen eine praktische und schnelle Lösung für jeden Bedarf dar. Das Treppenprofil ist gemäß Norm bis zu einer Breite von 1200 mm mit einer Last in der Mitte von 150 kg oder einer verteilten Last von 200 kg/m2 selbsttragend.

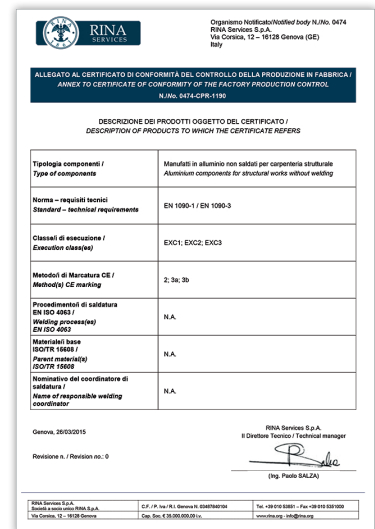
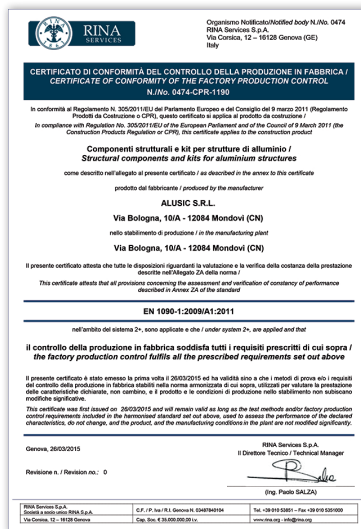

STAIRS, WALKWAYS AND CROSSOVER / SCALE E PASSERELLE / ESCALERAS Y PASARELAS / ESCALIERS ET PASSERELLES / TREPPEN UND ÜBERSTIEGEN / MONTAGESYSTEME

pag.7



pag.7



pag.9

SYMBOLS / SIMBOLI / SÍMBOLOS / SYMBOLES / SYMBOLE

Box
Scatola
Caja
Boîte
Schachtel



Load
Portata
Carga
Charge
Tragkraft

STAINLESS STEEL

Stainless steel product

Prodotto in inox
Producto de acero inoxidable
Produit en acier inoxydable
Produkt aus rostfreiem Stahl

ITALIAN PATENT

Patented product

Prodotto brevettato
Producto patentado
Produit breveté
Patentiertes Produkt

PATENT

NEW

New product

Prodotto nuovo
Nuevo producto
Nouveau produit
Neues Produkt

EN All profiles in the Alusic catalogue are extruded from EN-AW 6060 (Al Mg Si 0.5) primary aluminium alloy, or on request from EN-AW 6063 primary aluminium alloy. The aluminium used is supplied as T5/T6 temper (cooled from hot working/solution heat treated and artificially aged). The bars are normally supplied with a 12 µm anodising treatment (on request, most profiles can also be supplied as mill finish). The tolerances applied when extruding the profiles follow EN 12020-2.

IT Tutti i profili del catalogo Alusic sono realizzati per estrusione di lega di alluminio primario EN-AW 6060 (Al Mg Si 0.5) o a richiesta in lega di alluminio primario EN-AW 6063. Lo stato metallurgico di fornitura è T5/T6 (solubilizzato, temprato e invecchiato artificialmente). Le barre sono normalmente fornite anodizzate con profondità di trattamento in classe 12 µm (a richiesta la maggior parte dei profili può essere fornita grezza). Le tolleranze generali seguite per l'estrusione dei profili seguono la norma UNI-EN 12020-2.

ES Todos los perfiles del catálogo Alusic están fabricados mediante extrusión de aleación de aluminio primario EN-AW 6060 (Al-Mg-Si 0.5) o, bajo solicitud, en aleación de aluminio primario EN-AW 6063. El estado metalúrgico en que se suministran es T5/T6 (solubilizado, templado y envejecido artificialmente). Las barras normalmente se suministran anodizadas, con una profundidad de tratamiento de 12 µm (bajo solicitud, la mayor parte de los perfiles puede suministrarse en bruto). Las tolerancias generales conseguidas mediante la extrusión de los perfiles son acordes a la norma UNI-EN 12020-2.

FR Tous les profilés du catalogue Alusic sont réalisés par extrusion à partir d'alliage d'aluminium primaire EN-AW 6060 (Al Mg Si 0.5) ou sur demande en alliage d'aluminium primaire EN-AW 6063. L'état métallurgique de fourniture est l'état T5/T6 (solubilisé, trempé et vieilli artificiellement). Les barres sont fournies anodisées avec une profondeur de traitement en classe 12 µm (sur demande, la plupart des profilés peuvent être fournis bruts). Les tolérances générales appliquées à l'extrusion des profilés respectent la norme UNI-EN 12020-2.

DE Alle Profile des Alusic-Katalogs werden mittels Strangpressen aus der Primäraluminiumlegierung EN-AW 6060 (Al Mg Si 0,5) oder auf Anfrage aus der Primäraluminiumlegierung EN-AW 6063 hergestellt. Der metallurgische Lieferzustand ist T5/T6 (Lösungsgeglüht, abgeschreckt aus der Warmumformungstemperatur und warmausgehärtet). Normalerweise werden die Stangen dem Eloxalverfahren unterzogen und haben eine 12 µm dicke Schutzschicht (auf Anfrage sind die meisten der Profile auch ohne Eloxierung erhältlich). Für die Strangpressung der Profile wurden die allgemeinen Toleranzen der Norm UNI EN 12020-2 eingehalten.

CHEMICAL COMPOSITION OF ALLOYS

COMPOSIZIONE DELLE LEGHE / COMPOSICIÓN QUÍMICA DE LAS ALEACIONES

COMPOSITION CHIMIQUE DES ALLIAGES / CHEMISCHE ZUSAMMENSETZUNG DER LEGIERUNGEN

EN-AW	Cu	Fe	Mn	Mg	Si	Zn	Cr	Ti	Al
6060	0.10	0.1 - 0.3	0.10	0.35 - 0.6	0.3 - 0.6	0.15	0.05	0.10	dal 98% al 99%
6063	0.10	0.35	0.10	0.45 - 0.9	0.2 - 0.6	0.10	0.10	0.10	dal 97,5% al 98,5%

MECHANICAL PROPERTIES

CARATTERISTICHE MECCANICHE / CARACTERÍSTICAS MECÁNICAS

CARACTÉRISTIQUES MÉCANIQUES / MECHANISCHE EIGENSCHAFTEN

EN-AW	Rm (N/mm ²)	Rp0,2 (N/mm ²)	A (%)	HB
6060	190	150	8	70
6063	215	170	8	75

PHYSICAL PROPERTIES

CARATTERISTICHE FISICHE / CARACTERÍSTICAS FÍSICAS

CARACTÉRISTIQUES PHYSIQUES / PHYSIKALISCHE EIGENSCHAFTEN

E [N/mm ²]	69000
ρ [Ω mm/m]	0.033
λ W/mK	210
T _m (C°)	615 - 655
α (K ⁻¹)	25X10 ⁻⁶



STEP
SCALINO
ESCALÓN
MARCHE
STUFE

Cod	lx cm ⁴	ly cm ⁴	wx cm ³	wy cm ³	mm ²	Kg/m
084.101.065	22,89	1239,82	10,06	91,16	1486,23	4,01

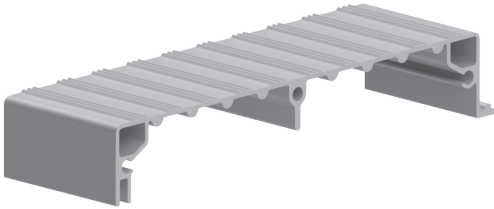

Anodised aluminium

Alluminio anodizzato
Aluminio anodizado
Aluminium anodisé
Eloxiertes Aluminium

L=6040 mm

Natural colour

Colore naturale
Color natural
Couleur naturelle
Natürliche Farbe

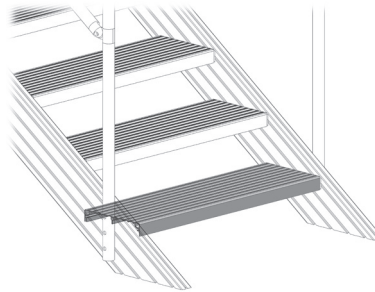
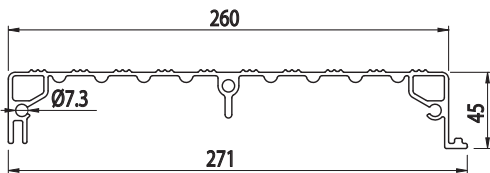

Ø40

Cod	lx cm ⁴	ly cm ⁴	wx cm ³	wy cm ³	mm ²	Kg/m
084.101.066	8,59	8,59	4,3	4,3	549,8	0,95



Anodised aluminium

Alluminio anodizzato
Aluminio anodizado
Aluminium anodisé
Eloxiertes Aluminium

L=6040 mm

Natural colour

Colore naturale
Color natural
Couleur naturelle
Natürliche Farbe

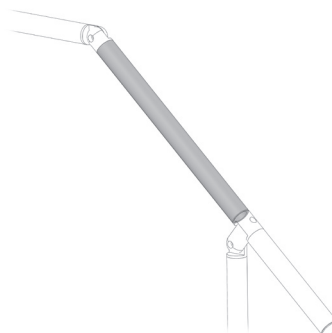
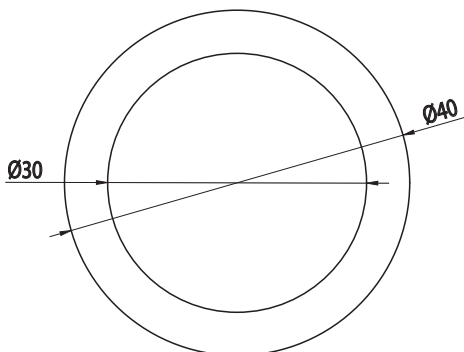

45x180



Cod	lx cm ⁴	ly cm ⁴	wx cm ³	wy cm ³	mm ²	Kg/m
084.101.022	48,33	689,89	21,48	76,65	2206	5,96

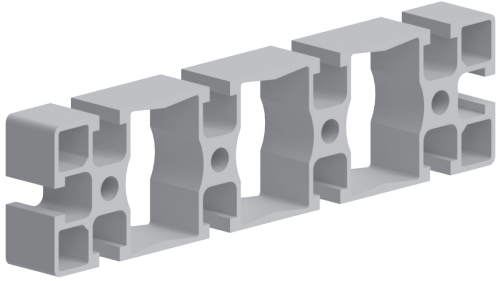

Anodised aluminium
 Alluminio anodizzato
 Aluminio anodizado
 Aluminium anodisé
 Eloxiertes Aluminium
L=6040 mm

Natural colour
 Colore naturale
 Color natural
 Couleur naturelle
 Natürliche Farbe

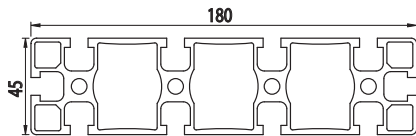

Tappo - Cap - Tapòn - Embout - Abdeckkappe			
Cod	Mat	g	Col
084.201.022	PA	23	■
084.201.022G	PA	23	■

**TWO-WAY JOINT**

GIUNTO 2 VIE
EMPALME DE 2 VÍAS
JOINT 2 VOIES
ZWEI-WEGE-VERBINDER

Cod	Note	g
084.313.005	For straight sections - Per tratti rettilinei - Para tramos rectilíneos - Pour sections rectilignes - Für gerade Abschnitte	140

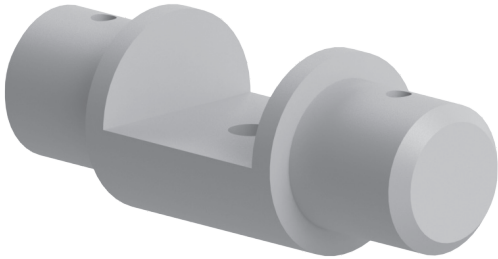
**Tumbled aluminium**

Alluminio burattato
Aluminio pulido
Aluminium poli au tonneau
Trowalisiertes Aluminium

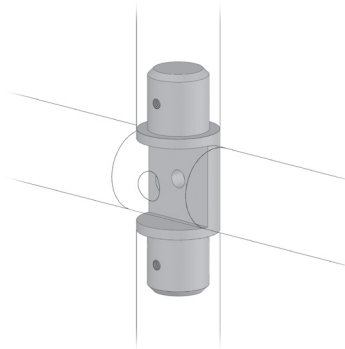
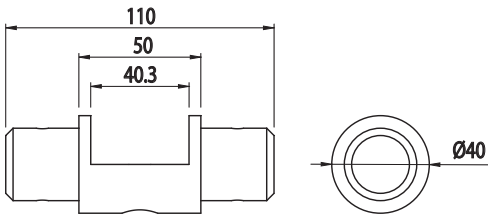
**TWO-WAY JOINT**

GIUNTO 2 VIE
EMPALME DE 2 VÍAS
JOINT 2 VOIES
ZWEI-WEGE-VERBINDER

Cod	Note	g
084.313.004	For angled sections - Per tratti inclinati - Para tramos inclinados - Pour sections inclinées - Für geneigte Abschnitte	200

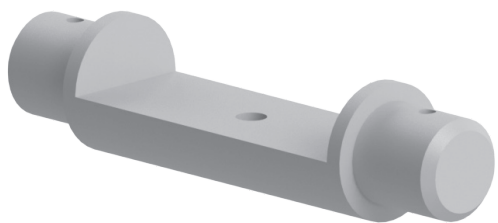
**Tumbled aluminium**

Alluminio burattato
Aluminio pulido
Aluminium poli au tonneau
Trowalisiertes Aluminium

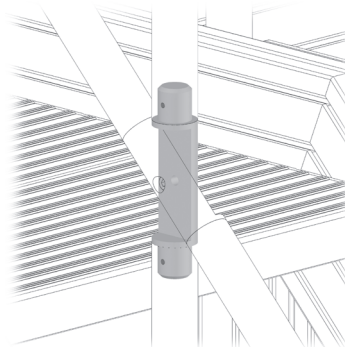
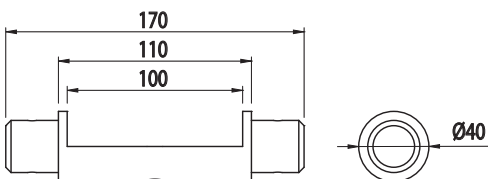

FIXED 3-WAY JOINT

GIUNTO 3 VIE FISSO
EMPALME 3 VÍAS FIJO
JOINT 3 VOIES FIXE
FESTER DREI-WEGE-VERBINDER



Cod	Note	g
084.313.003	For straight sections - Per tratti rettilinei - Para tramos rectilíneos - Pour sections rectilignes - Für gerade Abschnitte	180

Tumbled aluminium

Alluminio burattato
Aluminio pulido
Aluminium poli au tonneau
Trowalisiertes Aluminium

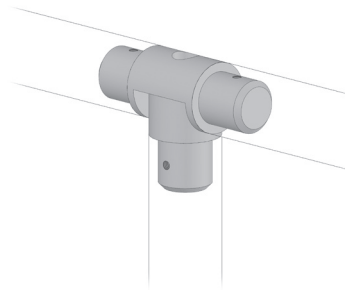
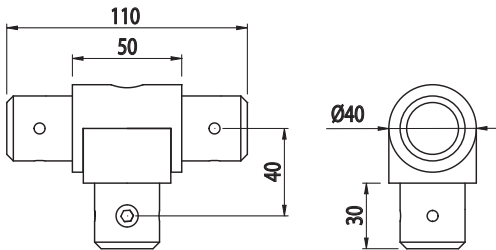

ARTICULATED 3-WAY JOINT

GIUNTO 3 VIE SNODATO
EMPALME 3 VÍAS ARTICULADO
JOINT 3 VOIES ARTICULÉ
DREI-WEGE-VERBINDER MIT GELENK



Cod	Note	g
084.313.002	For angled sections - Per tratti inclinati - Para tramos inclinados - Pour sections inclinées - Für geneigte Abschnitte	190

Tumbled aluminium

Alluminio burattato
Aluminio pulido
Aluminium poli au tonneau
Trowalisiertes Aluminium

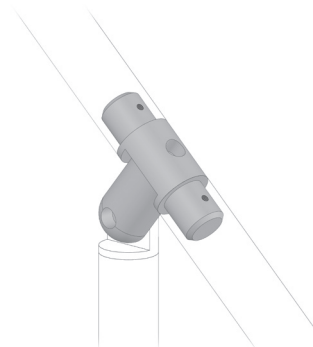
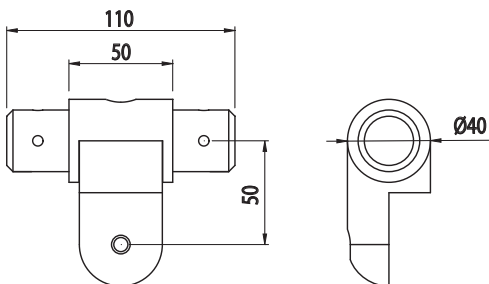

**ARTICULATED JOINT**

GIUNTO SNODATO
EMPALME ARTICULADO
JOINT ARTICULÉ
VERBINDER MIT GELENK

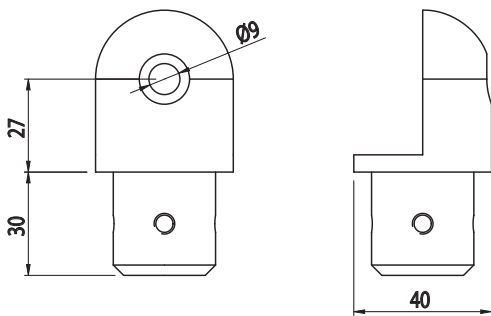

Cod	Note	g
084.313.001	For angled sections - Per tratti inclinati - Para tramos inclinados - Pour sections inclinées - Für geneigte Abschnitte	95

Tumbled aluminium

Alluminio burattato
Aluminio pulido
Aluminium poli au tonneau
Trowalisiertes Aluminium

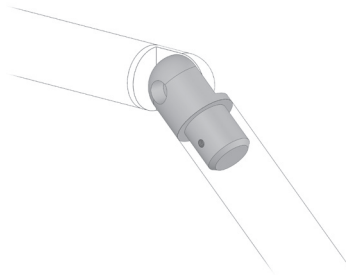
**90° JOINT**

GIUNTO 90°
EMPALME 90°
JOINT 90°
VERBINDER 90°

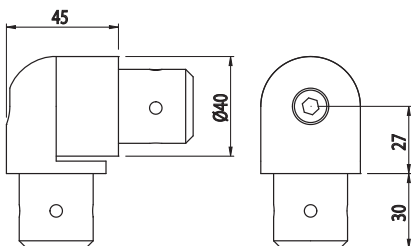

Cod	Note	g
084.313.106	For 90° connectors - Per giunzioni a 90° - Para uniones en 90° - Pour jonctions à 90° - Für 90°-Verbindungen	180

Tumbled aluminium

Alluminio burattato
Aluminio pulido
Aluminium poli au tonneau
Trowalisiertes Aluminium



PROFILE FASTENING KIT

KIT FISSAGGIO PROFILI
 KIT FIJACIÓN PERFILES
 KIT FIXATION PROFILÉS
 BEFESTIGUNGSKIT FÜR PROFILE

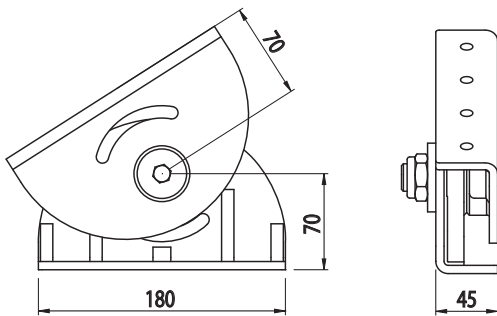
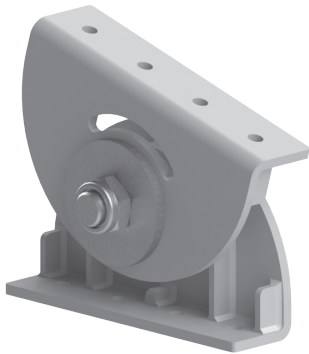

Cod	Note	g
084.313.006	Articulated joint for fastening 45x180 profiles - Giunto snodato per fissaggio profili 45x180 - Empalme articulado para fijación de perfiles 45x180 - Joint articulé pour fixation profilés 45x180 - Verbinder mit Gelenk für Befestigung der Profile 45x180	1920

Galvanised steel

Acciaio zincato
 Acero galvanizado
 Acier zingué
 Verzinkter Stahl

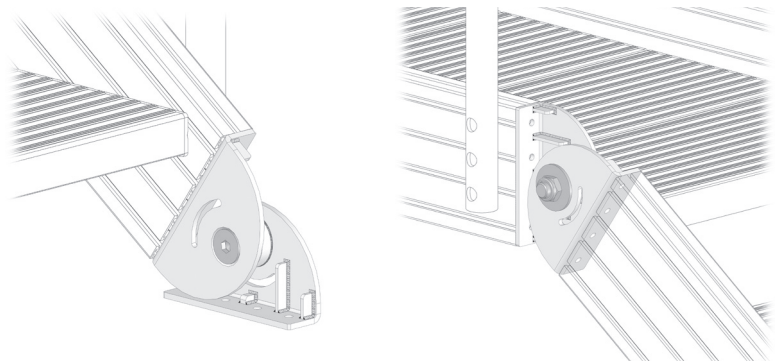

45° PLATE

PIASTRA 45°
 PLACA 45°
 PLAQUE 45°
 PLATTE 45°

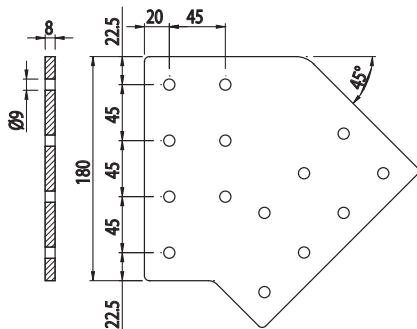
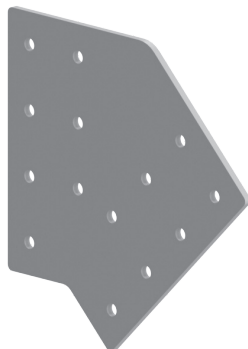

Cod	Note	g
084.313.013	Lateral plate for 45° steps - Piastra laterale per scala a 45° - Placa lateral para escalera en 45° - Plaque latérale pour escalier à 45° - Seitenplatte für Treppe 45°	1270

Galvanised steel

Acciaio zincato
 Acero galvanizado
 Acier zingué
 Verzinkter Stahl

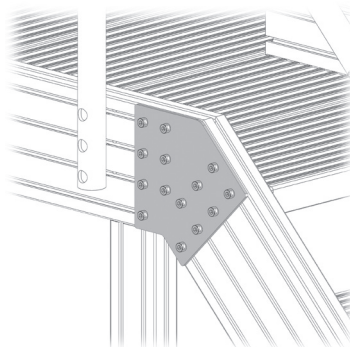

**PAIR OF STEP FIXING PLATES**

COPPIA PIASTRE FISSAGGIO SCALINO
PAR DE PLACAS DE FIJACIÓN ESCALÓN
PAIRE PLAQUES DE FIXATION MARCHE
PLATTENPAAR TREPPENBEFESTIGUNG

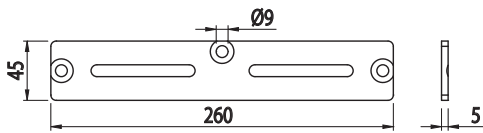
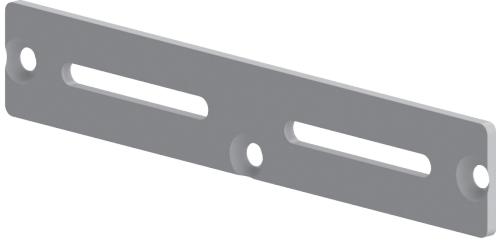

Cod	Note	g
084.313.007	Pair of plates for step fixing - Coppia piastre per il fissaggio dello scalino - Par de placas para la fijación del escalón - Paire plaques de la fixation de la marche - Plattenpaar für die Treppenbefestigung	810

Galvanised steel

Acciaio zincato
Acero galvanizado
Acier zingué
Verzinkter Stahl

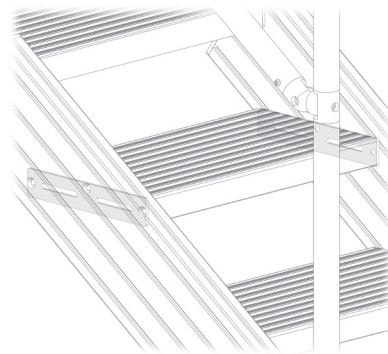
**JOINT CAP**

TAPPO GIUNTO
TAPÓN UNIÓN
BOUCHON JOINT
ABDECKKAPPE FÜR VERBINDER

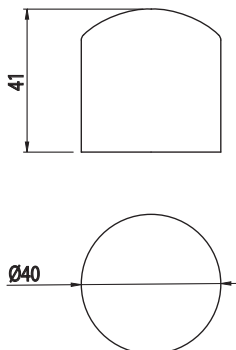

Cod	Note	g
084.313.010	Aluminium joint cap - Tappo per giunti in alluminio - Tapón para uniones de aluminio - Bouchon pour joints en aluminium - Abdeckkappe für Verbinder aus Aluminium	30

Black polythene

Polietilene nero
Polietileno color negro
Polyéthylène noir
Polyethylen schwarz

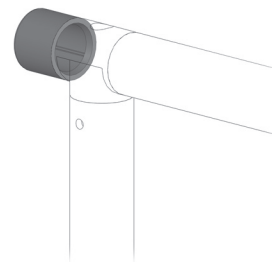

CAP
TAPPO
TAPÓN
BOUCHON
ABDECKKAPPE

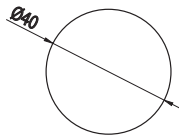
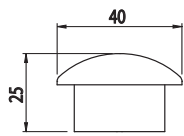

Cod	Note	g
084.313.008	Cap for profile 084.101.066 - Tappo per profilo 084.101.066 - Tapón para perfil 084.101.066 - Bouchon pour profilé 084.101.066 - Abdeckkappe für Profil 084.101.066	20

Black polythene
Polietilene nero
Polietileno color negro
Polyéthylène noir
Polyethylen schwarz

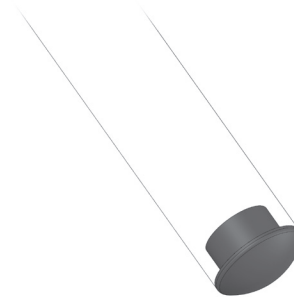

BRACKET FOR RAIL
STAFFA PER PARAPETTO
ESTRIBO PARA BARANDILLA
BRIDE POUR PARAPET
BÜGEL FÜR GELÄNDER

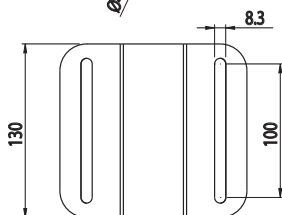
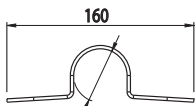

Cod	Note	g
084.313.009	Bracket for rail fastening - Staffa per fissaggio parapetto - Estribo para fijación de barandilla - Bride de fixation parapet - Bügel für Geländerbefestigung	30

Galvanised steel
Acciaio zincato
Acero galvanizado
Acier zingué
Verzinkter Stahl

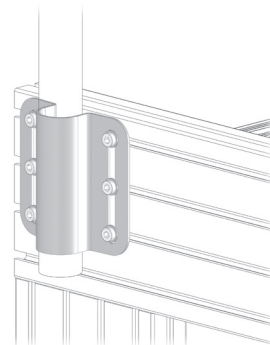



ESEMPIO DI PASSERELLA PER LO SCAVALCAMENTO DI UNA LINEA DI PRODUZIONE

EXAMPLE OF CROSSOVER STAIR

EJEMPLO DE PASARELA PARA CRUZAR UNA LÍNEA DE PRODUCCIÓN

EXEMPLE DE PASSERELLE POUR TRAVERSER UNE LIGNE DE PRODUCTION

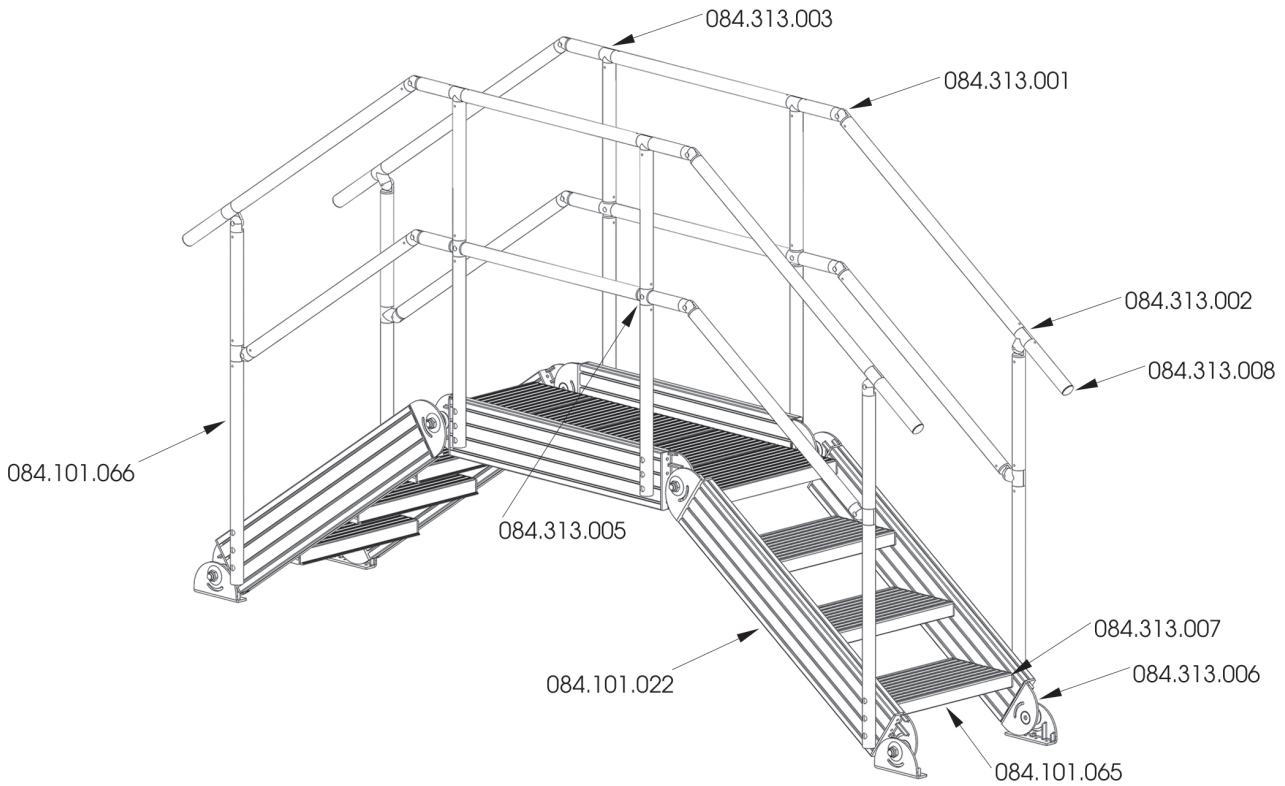
BEISPIEL EINER ÜBERSTIEGE ZUR ÜBERBRÜCKUNG VON EINER PRODUKTIONSLINIE



ESEMPIO DI SCALA CON PIANEROTTOLO

EXAMPLE OF STAIR WITH LANDING

EJEMPLO DE ESCALERA CON RELLANO

EXEMPLE D'ESCALIER AVEC PALIER

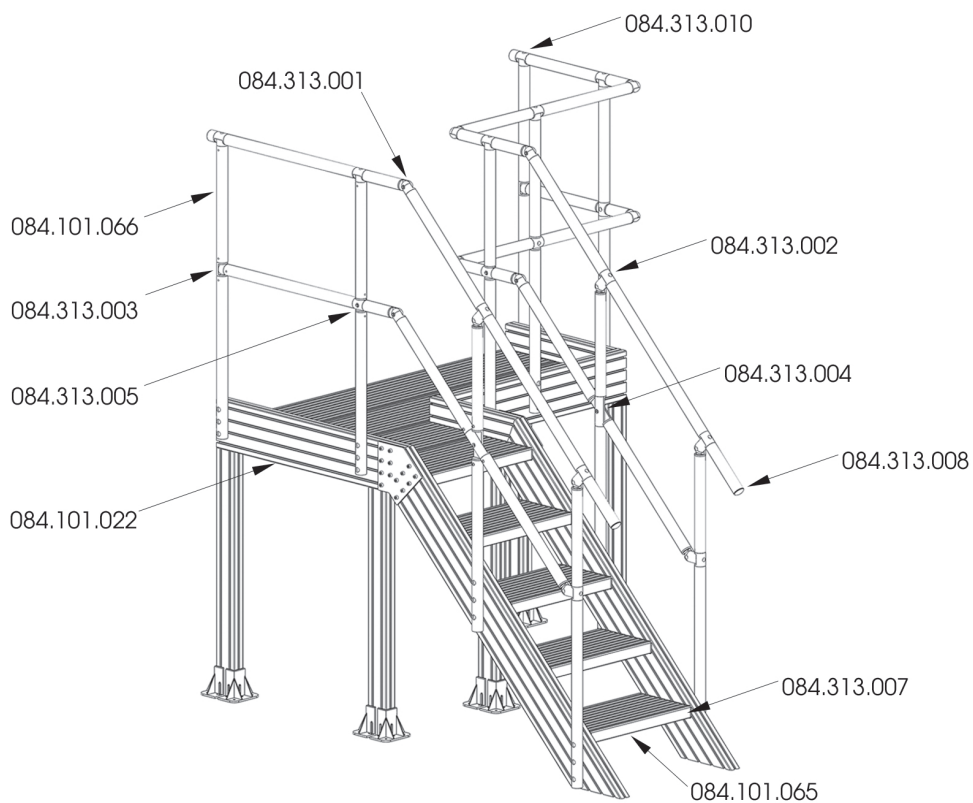
BEISPIEL EINER TREPPE MIT TREPPENABSATZ





ESEMPIO DI SCALA CON INCLINAZIONE FISSA

EXAMPLE OF FIXED SLOPE STAIR

EJEMPLO DE ESCALERA CON INCLINACIÓN FIJA

EXEMPLE D'ESCALIER AVEC INCLINAISON FIXE

BEISPIEL EINER FESTEN TREPPENSTEIGUNG

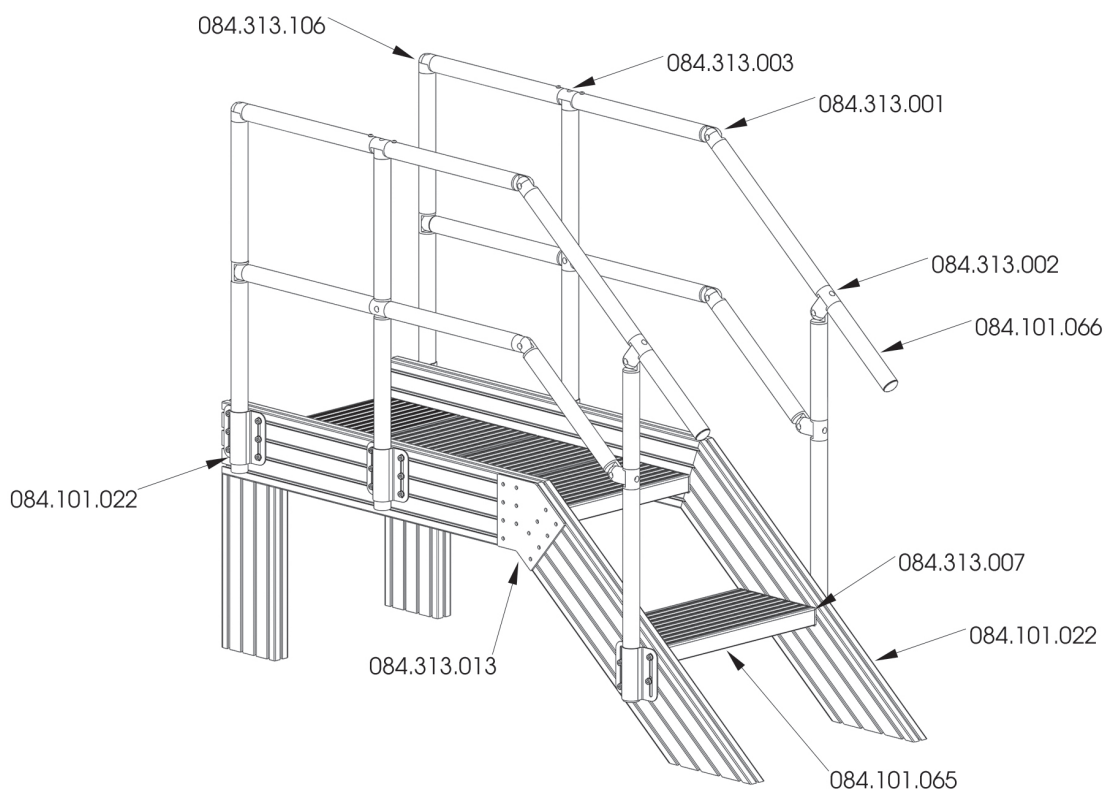

MONTAGGIO DEL TUBO

TUBE ASSEMBLY

MONTAJE DEL TUBO

MONTAGE DU TUBE

ROHRMONTAGE

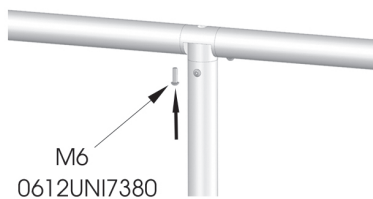
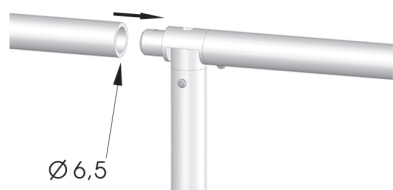



FISSAGGIO DEL PARAPETTO CON LAMATURA

GUARD FASTENING WITH COUNTERBORE
 FIJACIÓN AVELLANADA DEL PARAPETO
 FIXATION DU GARDE-CORPS AVEC LAMAGE
 MONTAGE DES GELÄNDERS DURCH SENKUNG

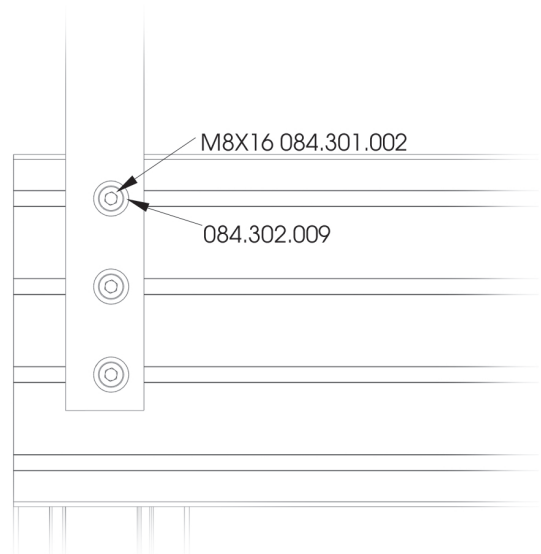
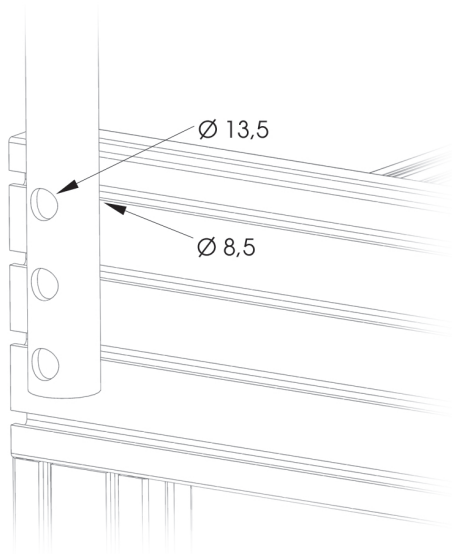

FISSAGGIO DEL PARAPETTO CON PIASTRA REGOLABILE

GUARD FASTENING WITH ADJUSTABLE PLATE
 FIJACIÓN DEL PARAPETO CON PLACA REGULABLE
 FIXATION DU GARDE-CORPS AVEC PLAQUE RÉGLABLE
 MONTAGE DES GELÄNDERS DURCH VERSTELLBARE PLATTE

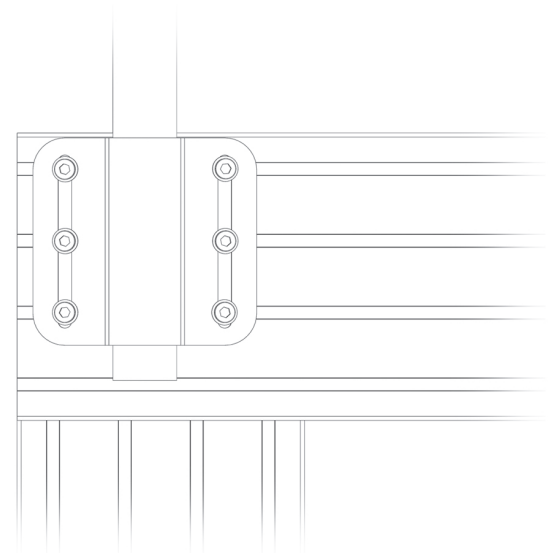
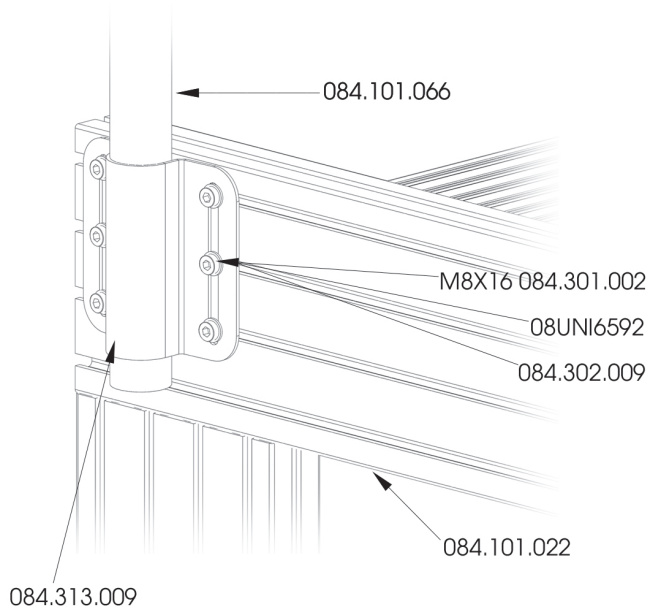



SISTEMA DI MONTAGGIO

ASSEMBLY SYSTEM
SISTEMA DE MONTAJE
SISTÈME DE MONTAGE
MONTAGESYSTEM

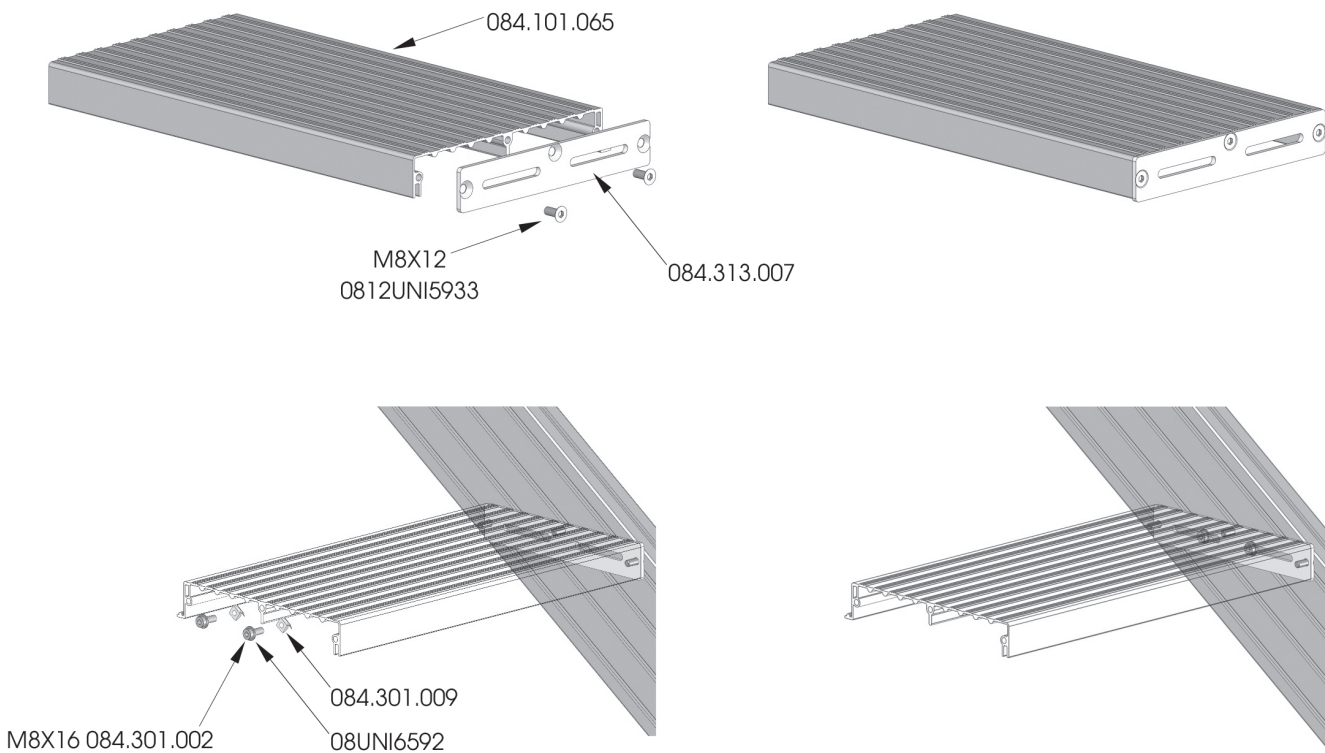

SISTEMA D'INCASTRO DELLO SCALINO PER LA REALIZZAZIONE DI UN PIANEROTTOLO

BOLTLESS STEP SYSTEM FOR LANDING
SISTEMA DE ENCLAVAMIENTO DEL ESCALÓN PARA LA REALIZACIÓN DE UN RELLANO
SISTÈME D'ENCASTREMENT DU MARCHE POUR LA RÉALISATION D'UN PALIER
STECKSYSTEM DER STUFE FÜR DIE UMSETZUNG EINES TREPPENABSATZ

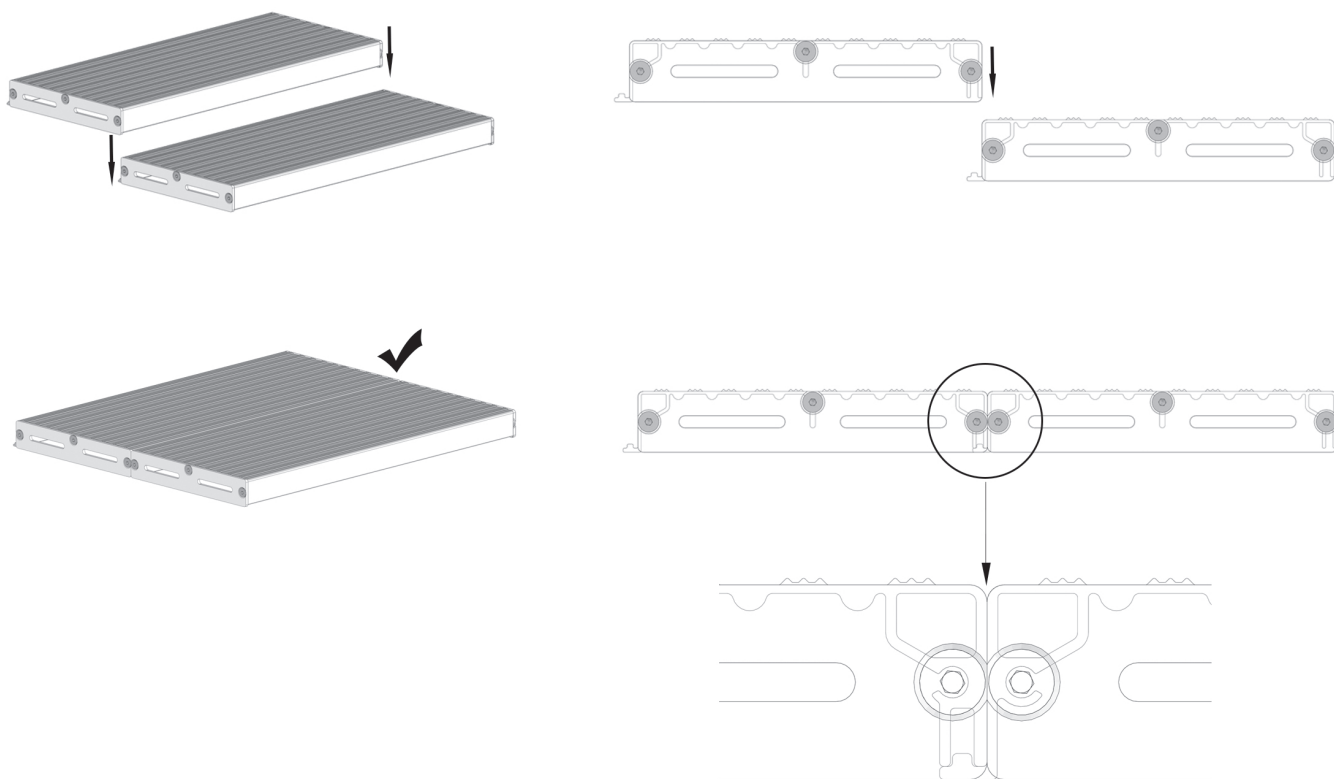



Alusic

INDEX

INDICE
ÍNDICE
INDEX
INDEX

CODE	PAGE	CODE	PAGE	CODE	PAGE
084.101.022	8				
084.101.065	7				
084.101.066	7				
084.201.022	8				
084.201.022G	8				
084.313.001	11				
084.313.002	10				
084.313.003	10				
084.313.004	9				
084.313.005	9				
084.313.006	12				
084.313.007	13				
084.313.008	14				
084.313.009	14				
084.313.010	13				
084.313.013	12				
084.313.106	11				







Progetto grafico e impaginazione Alusic, Mondovì (CN)
Finito di stampare nel mese di dicembre 2023
presso tipografia San Martino, San Martino in Rio (RE)

IS LINE
ED.13 UPD.01

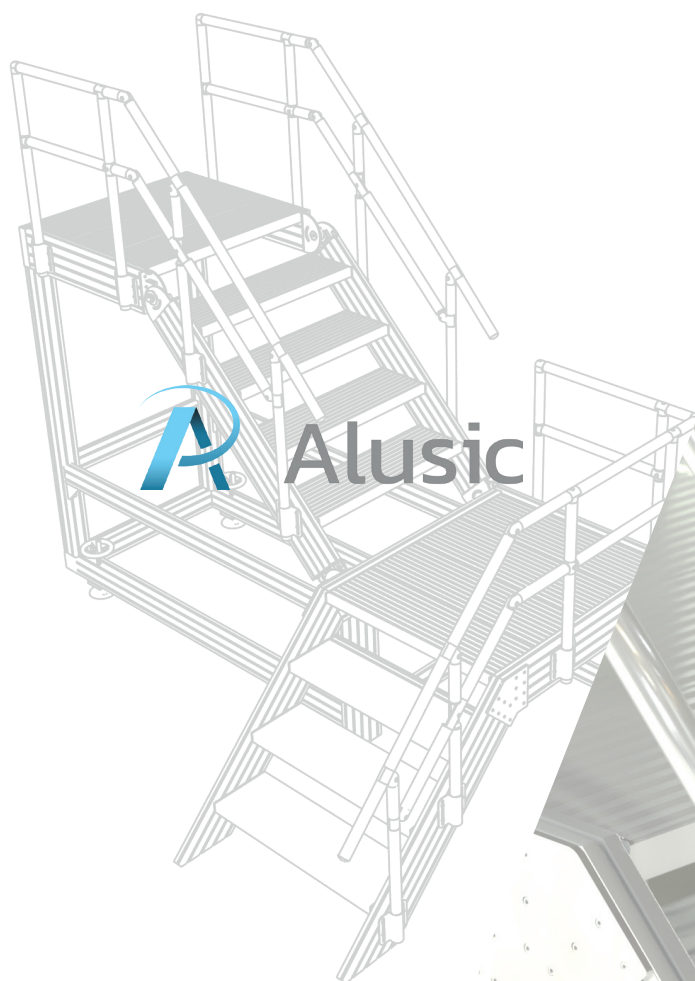

ALUSIC S.p.A.

VIA BOLOGNA, 10/D

12084 MONDOVÌ (CN) - ITALY

TEL.: (+39) 0174.55.29.49 - (+39) 0174.47.780

MAIL: contact@alusic.com

www.alusic.com

copyright - 01/2025